

Synchronous M a c h i n e s



TECO   **Westinghouse**

TECO-WESTINGHOUSE MOTOR COMPANY SYNCHRONOUS MACHINES

TECO-WESTINGHOUSE EXPERIENCE: ASSURING SUPERIOR PERFORMANCE AND RELIABILITY

For over a century, Westinghouse has been the pacesetter in the design and production of electric machines for heavy industry. This tradition is carried forward by **TECO-Westinghouse Motor Company**. Our engineering, design expertise, rigorous quality control, and testing procedures ensure the superior performance and unsurpassed reliability of each machine.

Since the late 19th century, Westinghouse has been the driving force behind the evolution of rotating electric machine technology. The long list of pioneering developments includes Vacuum Pressure Impregnation (VPI), Thermalastic® Epoxy insulation, self-lubricating bearings and brushless excitation. In the synchronous arena, **TECO-Westinghouse Motor Company** has a track record for excellence and innovation.

Designed to meet the needs of both domestic and worldwide motor markets, **TECO-Westinghouse Motor Company** synchronous machines are the culmination of more than 100 years of experience from the acknowledged leader in rotating electric machine technology.



SYNCHRONOUS MACHINES: THE OPTIMAL CHOICE FOR HEAVY INDUSTRY

TECO-Westinghouse Motor Company synchronous motors and generators provide superior value with proven reliability, low maintenance performance and long life in arduous applications. Our synchronous machines offer numerous benefits including:

- Constant-speed operation
- High efficiency ratings
- Low inrush currents
- Leading power factor (for corrective KVA capability)

These features make synchronous machinery the optimal choice for many industrial drive applications.

Synchronous motor efficiencies are higher than those of induction motors. Their inrush currents are low and they can be designed with torque characteristics to meet the requirements of the driven load and available power supply. Starting, pull-in and pull-out torques can be selected over a wide range, and for short time periods the pull-out torque can even be increased by field forcing without affecting any other performance characteristics.

In general, synchronous motors have less of a system voltage drop during start-up than induction motors.

Power factor improvement is one of the most attractive considerations in selecting a synchronous machine. Synchronous motors operate at leading power factors and are typically available with rated power factors ranging from unity to 0.80 leading. Thus they can produce substantial savings by supplying reactive power to counteract lagging power factor caused by other inductive loads. Synchronous condensers are offered as a reliable alternative to power factor capacitor systems.

- 1 Municipal Clearwater Pumping Facility - (12) 6000 HP Vertical Synchronous Variable Frequency Drive Motors, up to 450 RPM

SYNCHRONOUS APPLICATIONS

TECO-Westinghouse Motor Company synchronous machines are customized to the specific requirements of each application. Because of their unique features, high operation efficiencies and adaptability to all working environments, synchronous motors and generators are the logical choice for a multitude of industries. These industries include the pulp, paper processing, electric utility, marine, water processing treatment, waste water treatment, chemical, petrochemical, steel, mining, cement, air conditioning and air separation industries.

Synchronous motors can be found wherever there is a demand for highly efficient, cost-effective, dependable machines. They are frequently used for chippers, mixers, crushers, pulverizers, rolling and grinding mills, pulp refiners, pumps, fans, and compressor drives, as well as adjustable-frequency drive equipment. With all of the advancements made in adjustable frequency drive technology, the variable speed synchronous motor is a logical choice for applications requiring high torque at low speed with a wide speed range.

Because of the higher efficiency, smaller size and higher output capability, the synchronous motor is replacing the DC motor as the driver in high performance applications.

Synchronous generators can be found in any number of applications, including gas, hydro, wind and turbo expansion systems.

Synchronous condensers are available to provide a local grid system with necessary KVARs required to balance highly inductive loads, thereby reducing power company imposed demand charges and power factor penalties.



FEATURES FOR EFFICIENT PERFORMANCE

TECO-Westinghouse Motor Company synchronous machines feature high efficiency designs in which great care is taken to minimize losses. To ensure maximum operating efficiencies and trouble-free operation, the following features are standard:

- Airgap, slot openings and slot ratios are selected to reduce pole face losses due to flux pulsations.
- Low loss, core-plated, non-aging, silicon steel stator punchings are used to reduce core losses.
- The stator copper is stranded to minimize eddy current losses.
- The number of stator slots, slot width, slot depth and stator core depth are dimensioned to reduce magnetic noise.
- Pole punchings are designed for reduced pole leakage flux and field excitation which reduce field copper losses from field excitation.
- Blowers are carefully selected to reduce windage loss.
- Stator end-plates are designed to insure a tight and rigid core assembly, to minimize noise due to core distortion and to transmit torque to the frame bulkhead.

1

Refinements to process and designs have led to the development of smaller, more efficient synchronous motor

TECHNICAL FEATURES

BRUSH EXCITATION

TECO-Westinghouse Motor Company synchronous machines are available with brush rigging and collector rings. The complete assembly is designed for long life and is easily accessible for inspection and routine maintenance.

Made of steel or cooper alloy, the collector rings are shrunk onto a steel mandrel over a Micarta® insulation sleeve. The assembly is held in place on the rotor shaft by a tight press fit. To ensure permanent concentricity, collector ring surfaces are machine finished and polished after assembly.

The brush rigging consists of cast-brass brushholders mounted on insulated steel rods and supported from the bearing pedestal. The number of brushes for a particular size and rating depends on the field current. Sufficient brushes are supplied to limit the current density to a low value for trouble-free operation. Brushes are of the electrographitic type and are specially selected for each application.

BRUSHLESS EXCITATION

Brushless excitation with our exclusive PULSE/SYN® control is available for fixed speed and line start applications. It is well suited for installations such as refineries and chemical process plants that require low maintenance and the elimination of sparking. This brushless excitation system consists of a field discharge resistor, diodes, SCR's, a gating module and a synchronizing module. The discharge resistor is shunted across the rotor field during starting. At the proper slip and proper phase angle, the resistor is removed automatically from the field current and DC current is applied to the field to pull the rotor into synchronism.

The key to the PULSE/SYN® system is the synchronizing module. This module has two separate functions. The first function is phase angle synchronization. The module monitors rotor speed (by frequency of induced field voltage) and rotor phase angle (by phase angle of induced voltage). When the speed and phase angle are such as to cause minimum disturbance to the supply system, the field voltage is applied and the motor “pulls-in” synchronous.

The second function of the synchronization module is to handle the occurrence of “post-synchronization.” This is when a motor synchronizes by reluctance before the field voltage is applied. The module monitors the rotor speed and excitation voltage. When the frequency of induced field voltage is zero for a pre-determined time and excitation voltage is available, the field voltage is applied to the motor field. This action places the rotor in proper phase position and synchronization.

ROTOR CONSTRUCTION

TECO-Westinghouse Motor Company rotors are recognized as some of the most reliable in the industry. Their high performance standards are a hallmark of TECO-Westinghouse Motor Company synchronous machines. Rotor amortisseur windings are fabricated copper or copper alloy bars brazed to copper resistance ring segments. Rotor bars and slots are sized to assure tight bar construction, thus eliminating bar vibration.

STATOR LAMINATIONS

Stator laminations are accurately manufactured from thin, non-aging, high grade precoated silicon steel, that has been insulated on both sides to minimize core losses. The stator core is built up from these silicon steel punchings and held under pressure between two endplates. Additionally, a set of core bars are welded to the stator core and to the endplates to insure tightness, torsional stiffness, and adequate transmission of airgap torque to the motor foundation. The result is a permanently tight and concentric core with uniform airgap. An exclusive punching design prevents the laminations from becoming dislodged.



THERMALASTIC® INSULATION

The stator insulation system for **TECO-Westinghouse Motor Company** synchronous machines is Thermalastic® Epoxy Insulation. This premium insulation system, developed by Westinghouse, has been proven with more than 50 years of outstanding performance on thousands of Westinghouse and **TECO-Westinghouse Motor Company** machines.

Thermalastic® insulation is under continuous development to maintain its position as the world's finest insulation system. The outstanding record of Thermalastic® insulation can be attributed to the fact that it is a mica-based insulation system. Mica has long been recognized as the most reliable insulating material due to its superior dielectric and voltage endurance capabilities. Careful manufacturing procedures, including rigorous testing at critical points in the process, assure a distinctly superior insulation system.

First, mica insulation is applied to the form-wound stator coils. The coils are then installed in the slots. Then the completely wound stator is post-impregnated with epoxy resin in a vacuum pressure tank. Next, it is transferred to a baking oven for resin polymerization. The cycle is repeated for double protection. The result is a stator insulation system free of corona-generating voids, able to withstand prolonged voltage stresses, moisture, abrasion, dirt, thermal cycling and frequent starting surges.

Various types of Thermalastic® insulation are used depending on the physical size and voltage rating of the machines. On machines over 7000 volts, slot sections of the insulated coil are wrapped with a semi-conducting tape which, in conjunction with a corona-suppressing semi-conducting coating applied at the ends of the straight portion, protects the stator from corona damage. For very large diameter machines, Thermalastic® insulation is applied to individual coils. Each coil is impregnated with solventless resin and cured before being wound into stator core slots. An additional resilient elastometric outer coating is available for applications in which the insulation is subjected to abrasive atmospheres.

1

OPPOSITE PAGE

Brush type slip ring assembly with viewing window

2

Advanced split-sleeve bearings are precision-crafted using quality materials

BEARING SYSTEM

The bearing system has been engineered for continuous, reliable performance and easy maintenance. Sleeve-type bearings and oil rings are split to provide accessibility for visual inspection and maintenance. A void-free centrifugally cast babbitt is bonded to thick-walled bearing shells designed with spherical seating surfaces. Carefully balanced bronze oil rings and oil-accumulating grooves in babbitt-lined oil ring guides provide a liberal supply of lubricant to the bearing.

The bearing unit includes a four-part bearing seal system designed to prevent unwanted leaks. The seal system consists of an inner and outer floating labyrinth oil seal and an inner and outer air seal. These seals work together to contain oil in the bearings while keeping dirt and contaminants out.

TESTING

TECO-Westinghouse Motor Company synchronous motors and generators are tested to ensure compliance with specific performance requirements. Standard commercial tests per NEMA MG1-21.21 include a check of winding resistances, mechanical vibration, insulation resistance, bearing temperature rise and airgap measurement. When required, testing procedures include noise tests per IEEE 85, as well as a complete engineering performance test per IEEE 115 to determine machine efficiency, temperature rises, starting characteristics and other parameters.



DESIGNED TO MEET YOUR SPECIFIC APPLICATION

HIGH SPEED SYNCHRONOUS MACHINES (1800 RPM AND 1200 RPM)

- Solid shaft / spider forging is utilized for maximum strength.
- Dovetail pole construction ensures secure attachment to the shaft.
- Amortisseur windings with a copper damper segment attached to the damper bars, a shaped copper interconnect between adjacent poles and a steel retaining ring attached to the damper assembly for support.
- Edge-bent, strap-wound field coils with thermosetting resin-enriched turn insulation.
- Wire wound field coil bonded by a thermosetting resin.
- Brushless excitation system with a stationary DC field and 3 phase AC armature mounted on the rotor, complete with diodes and field application circuits to apply DC to the rotor field.
- Spherically-seated, self-aligning split-sleeve type bearings.
- Bracket or pedestal-type construction.



1
Brushless exciter control wheel

2
Heavy-duty retaining ring ensures mechanical rigidity

3
Poles with dovetail design.

SLOW SPEED SYNCHRONOUS MACHINES

- | Fabricated spider with bolted-on poles; the spider rim is hot-rolled and welded to the spider web in a continuous circular ring.
- | Spider shrunk on the shaft.
- | Shaft made from solid forgings.
- | Wire wound field coils are typically insulated with double dacron glass over copper. Each layer of the field coil is bonded by a thermosetting resin.
- | Bracket-type, two-bearing, pedestal construction or engine-type with single bearing and flanged shaft.
- | Brush or brushless exciter.
- | Poles with high strength rectangular bars inserted to hold pole laminations together and give stiffness to the pole.
- | Optional stator shift capability for easy maintenance.
- | Extra heavy construction is utilized on severe duty applications such as stiffening gussets welded to the spider web.
- | Wound poles secured to the spider rim by bolts extending through the rim and threaded into the bar.

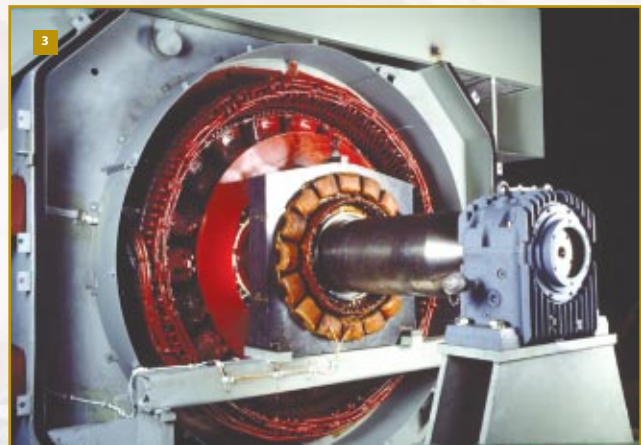
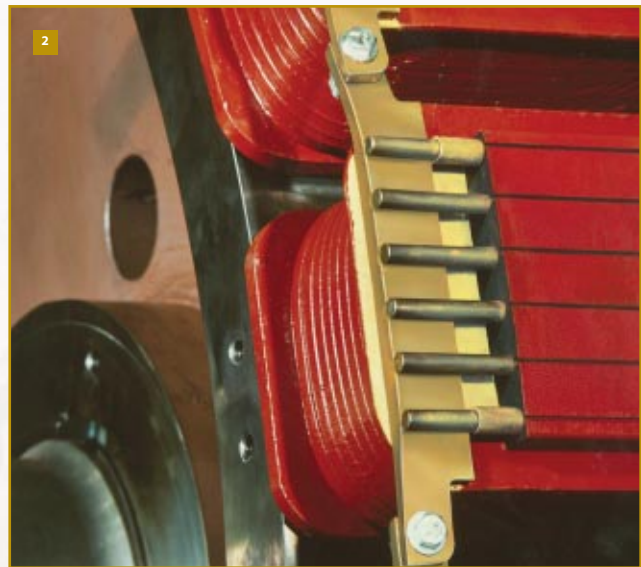
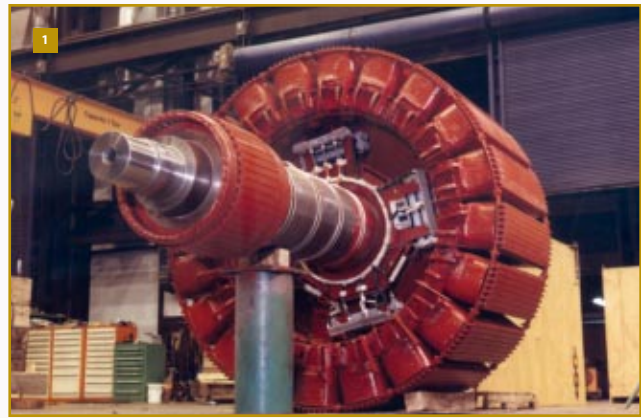

1
Brushless exciter rotor mounted on shaft of low speed synchronous motor

2
Poles mounted on spider rim

3
Slow speed pedestal bearing machine with brushless exciter rotor and stator

4
Spider rim used to hold poles on slow speed motor

ENGINE - TYPE SYNCHRONOUS MOTORS

On engine-type synchronous motors the driven equipment manufacturer typically furnishes the motor shaft and motor bearings. A solid hub is utilized for maximum mechanical strength. Overhung and flange-mounted construction are also available.

- Stator laminations are accurately manufactured from thin, non-aging, high-grade, pre-coated silicon sheet steel.
- Stator cores are built from silicon steel punching shields under pressure between two endplates.
- Spacer bars are welded between the endplates to prevent dishing and improve torsional stiffness of the core.

- Rotors are constructed of a thick steel hub, a vertical center plate or web and an outer spider rim.
- Wire wound field coils are insulated with double dacron glass over copper. Each layer of the field coil is bonded by a thermosetting resin.
- Poles are manufactured with high strength bars inserted along their length to increase stiffness.
- Wound poles are secured to the spider rim by bolts extending through the rim and threaded into the rectangular bar.

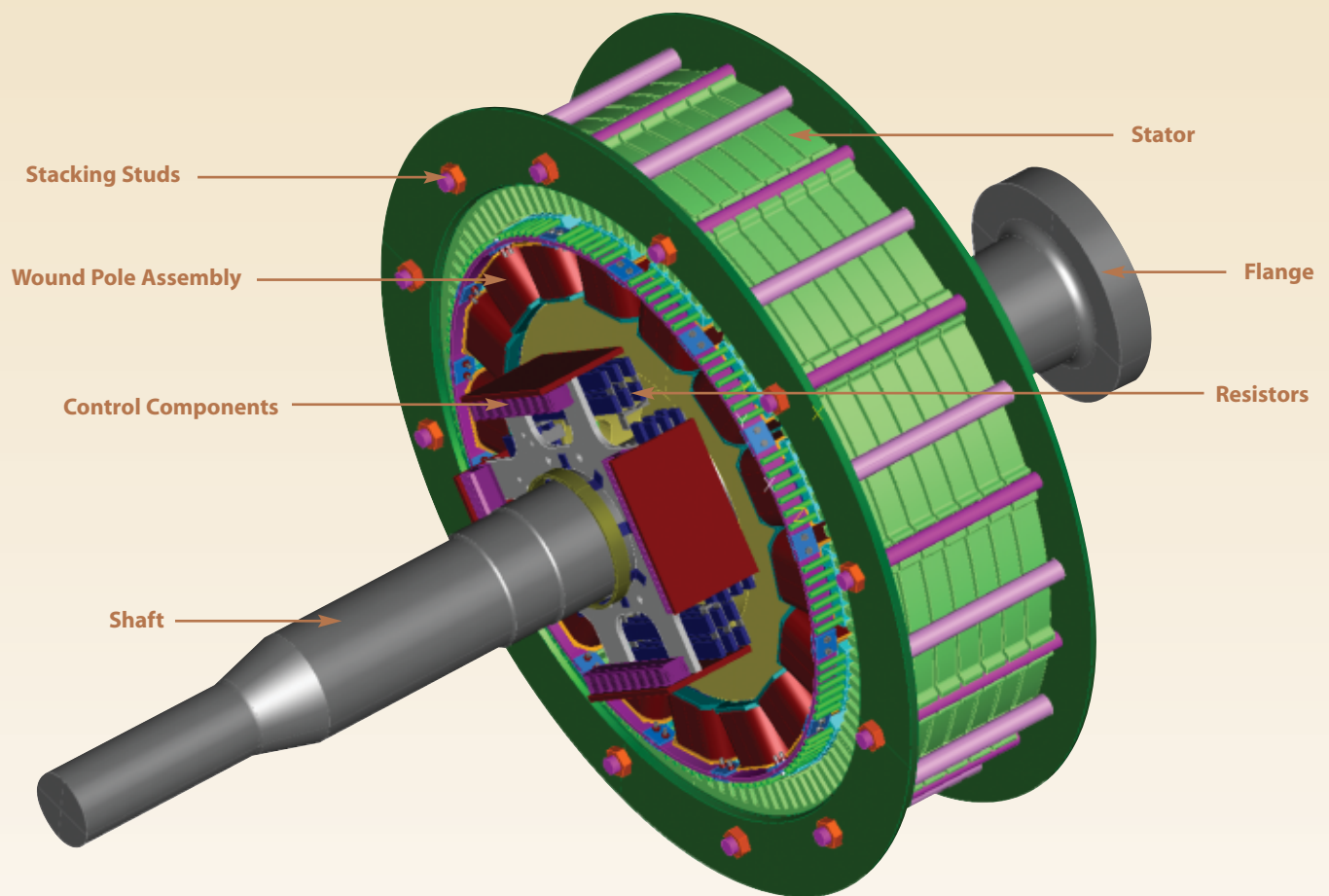

ADJUSTABLE FREQUENCY APPLICATIONS

Westinghouse pioneered the application of adjustable frequency, adjustable speed, brushless synchronous AC drives. With Load Commutated Inverters (LCI), a large synchronous motor can be used to power almost any type of driven equipment including fans, pumps, compressors or ship propulsion applications. These motors are designed to operate within conservative temperature limitations on centrifugal applications and provide precise speed control on constant torque applications.

TECO-Westinghouse Motor Company's adjustable frequency synchronous motors can be either 3 or 6 phase for either 6, 12 or 24 pulse drives. Full voltage, across the line start capability is available on some applications. These motors are available in either horizontal or vertical arrangements. Typical use is for applications requiring high power ratings, broad speed ranges, fast response and high efficiency.

TECO-Westinghouse Motor Company offers cycloconverter-powered synchronous motors. These motors are not just modified versions of industrial motors but are specifically designed electrically and mechanically for heavy-duty rolling mills. They include many of the mechanical features that have proven successful in **TECO-Westinghouse Motor Company** DC motors such as single or multiple armature configurations and also twin drive arrangement. The rotation can be either unidirectional or reversing. A wide variety of ventilation configurations are available, including integral ventilation.



1

Pedestal mounted bearing on bedplate

2

12 pole synchronous rotor (60,000 HP) showing rugged spider and shaft construction

GUIDELINES FOR SYNCHRONOUS MOTOR SELECTION

TECO-Westinghouse Motor Company synchronous motor can be designed to handle almost any type of load. Proper motor application is essential in achieving reliable performance. The following critical items should be considered when specifying the motor:

- Horsepower, speed, voltage and frequency
- Load characteristics for starting and running conditions
- Source of power, including requirements for power factor correction, and current that the power system can tolerate during start-up
- Fixed speed or adjustable speed operation
- Source of motor excitation
- Mechanical installation details such as foundations and crane capabilities
- Any features at the plant site that may affect the type of motor enclosure

STATOR SHIFT

Available for pedestal and engine-type machines, a stator shift requires a shaft and bedplate or soleplates of sufficient length to permit moving the stator toward the front (non-drive) bearing. Thus, the rotor can be uncovered without disconnecting the motor from the driven equipment for repair and/or maintenance.

1
Slow speed brush type machine with stator shift mounted on bedplate

POWER FACTOR

TECO-Westinghouse Motor Company synchronous machines can be designed with power factor ranging from Unity (1.0) to zero. The most common are 1.00 and 0.80.

ENCLOSURES

TECO-Westinghouse Motor Company synchronous motors and generators are supplied with a complete range of NEMA or IEC enclosures to meet the toughest environmental demands of industry, including hazardous locations. Available NEMA enclosures including the following configurations:

ENCLOSURE	NEMA	IEC STANDARD	IEC COOLING
Open	Open	IPOO	IC-01
Drip Proof	DP	IP12	
Drip Proof Fully Guarded	DPFG	IP22	IC-01
Drip Proof Guarded	DPG	IP22	IC-01
Splash Proof	SP	IP23	IC-01
Weather Protected I	WPI	IP24	IC-01
Weather Protected II	WPII	IP24	IC-01
Totally Enclosed, Water to Air Cooled	TEWAC	IP54	ICW-86
Totally Enclosed, Air to Air Cooled	TEAAC	IP54	IC-48
Totally Enclosed, Force Ventilated	TEFV	IP54	IC-37



TERMINAL BOXES

Synchronous machines feature main lead terminal and auxiliary boxes constructed of 11-gauge steel. Each terminal box is gasketed for air-tight, dust-free and weather-proof protection of terminal leads. Available for F1 and F2 locations, terminal boxes can be modified to accommodate any customer terminations and accessory devices.

ACCESSORIES

The following optional accessories are commonly added to **TECO-Westinghouse Motor Company** synchronous machines:

- | Stator resistance temperature detectors
- | Bearing resistance temperature detectors
- | Exciter control panel
- | Space heaters
- | Lightning arrestors
- | Differential current transformers
- | Ammeter current transformers
- | Air filters
- | Surge protection capacitors
- | Stator shift
- | Bearing vibration detectors
- | Partial Discharge Sensor

A WIDE CHOICE OF FRAME TYPES

VERTICAL

Vertical mounting configurations have a solid shaft with a coupling at the bottom. Kingsbury-type thrust bearings or antifriction bearings are available, depending on the thrust loadings and required life expectancy. Vertical machines can be designed to meet a wide range of thrust requirements.

HORIZONTAL BRACKET

Bracket-type machines have bearings mounted integral to the motor frame. These stand-alone type machines do not require a bed plate. Both laterally and torsionally, the frame is braced with bulkheads and stiffeners that provide structural stability for supporting the stator core and bearings. Reinforced steel plate end brackets are bolted and dowelled to the end bulkheads of the frame, providing rigid support directly under the bearings.

HORIZONTAL PEDESTAL

Pedestal designs are used when the rating or application requires a larger frame. A heavy, fabricated-steel bedplate and large bearing pedestals make this a particularly rugged mechanical construction. Low shaft height can be obtained even on extremely large machines by allowing part of the stator to extend below the bedplate. Engine-type motors are partial motors utilizing pedestal type construction features for the stator and rotor.

QUALITY FEATURES AND PROVEN PERFORMANCE

TECO-Westinghouse Motor Company synchronous machines combine the best of both innovative and time-proven technologies, including Thermalastic® Epoxy Insulation, brushless excitation and rugged rotor construction. This blend of advanced and traditional features makes **TECO-Westinghouse Motor Company** synchronous machines the optimal choice, as well as the best value, for heavy industry applications anywhere in the world.

Each synchronous machine is backed by over 100 years of design experience and industry leadership, as well as the expertise of our worldwide field service and engineering organization. Discover how the efficiencies and economies of **TECO-Westinghouse Motor Company** synchronous machines can enhance your application.

For more information, contact your local **TECO-Westinghouse Motor Company** representative or call toll free: **1-800-451-8798**.

